

Configurations

Transport Direction : Upwards Downwards

Direction of Entry/Exit : A B C D E F G H



Please fill out the form below with information.

1. Height of Entry/Exit : H1_____mm H2_____mm
2. Product Length : _____mm Long side leading
3. Product Width : _____mm Wide side leading
4. Product Height : _____mm
5. Product Weight : _____Kg Spacing : _____mm
6. Temperature in Contact Zone : _____°C
7. Conveying Speed : _____-_____M/min
Whether the speed is adjustable or not, frequency converter is installed as standard equipment.
8. Brand of Frequency Converter :
No specific brand Specified brand : _____
9. Conveyor Frame Materials : Stainless steel Painted Mild steel
10. Packing Materials :
Thermoplastic Film Cardboard Plastic Fabric Wood Metal Other : _____
11. Voltage & Frequency : _____V _____Hz
12. Brand of Motor : No specific brand SEW NORD BONFIGLIOLI MOTOVARIO
If not specified, SEW motor is installed as the standard drive.

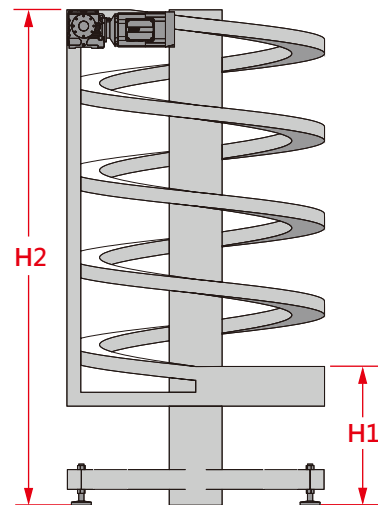

Specification

- The maximum number of turns is 12, and the maximum height of spiral conveyor is 12 m.
- Maximum temperature in contact zone between conveyor belt and products is 50° C. Special heat-resistant materials are available for purchase, please specify if required.
- Please be mindful that the safe range of total load capacity of mild-steel transmission chain is within 1200 Kg, and the safe range of total load capacity of stainless-steel transmission chain is within 1000 Kg.
- The recommended maximum conveying speed of this conveyor is 60 M / min, and lubricator is a standard device. The movable parts and consumables of the special model that exceeds this recommended speed are not included in the one-year warranty.

Contact Information

Company Name : _____
 Contact Person : _____ Department : _____
 Phone : _____ Fax : _____
 Website : _____ Email : _____