

Miniature Conveyor Questionnaire

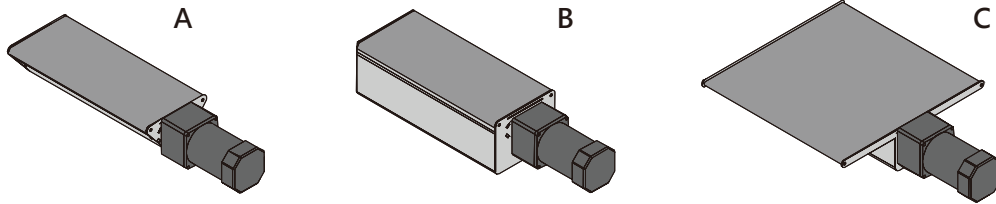

Please fill out the form below with information

1. Configuration : A B C
2. Belt width : (W) _____mm
3. Length of conveyor : (L) _____mm
4. Product Dimension L : _____mm
5. Product Dimension W : _____mm
6. Product Dimension H : _____mm
7. Product weight : _____Kg
8. Product Spacing : _____mm
9. Operating temperature : _____°C
10. Max. Speed : _____M/Min
11. Speed adjustable : Required Not Required
12. Voltage · Frequency : _____V _____Hz
13. Other requirements : _____

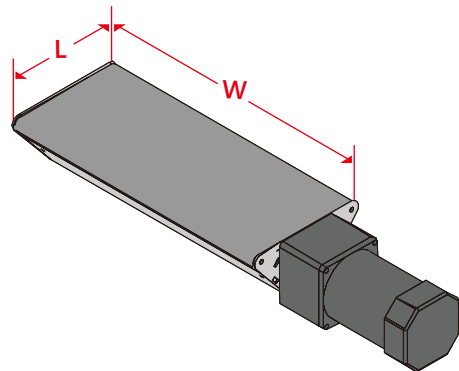

Specification

- The maximum manufacturing length of this conveyor is 3M, and the belt width ranges from 30 mm to 1500 mm .
- The maximum load capacity of this conveyor is 250 Kg / M (belt width) · and the maximum speed is 60 M / min.
- Standard frame material of miniature conveyor is stainless steel.

Contact Information

Company Name : _____

Contact Person : _____ Department : _____

Phone : _____ Fax : _____

Website : _____ Email : _____