

## Curve Conveyor Questionnaire

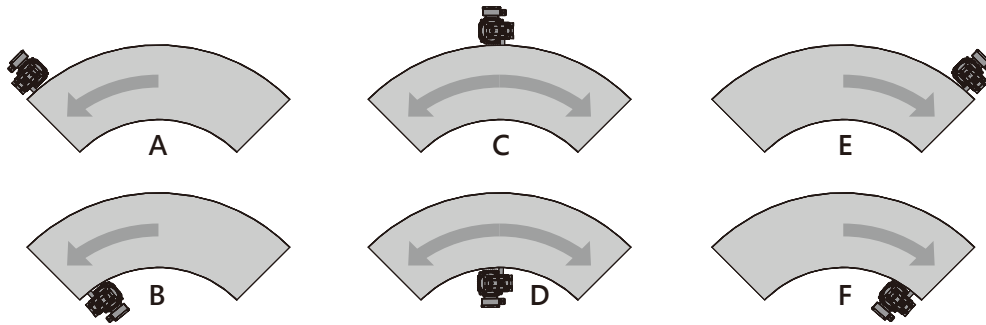

**Please fill out the form below with information**

1. Configuration : A B C D E F
2. Turning Angle :  45°  60°  90°  135°  180°
3. Belt width( W ) :  200mm  400mm  600mm  
 800mm  1000mm  Other\_\_\_\_\_
4. Height ( H ) : \_\_\_\_\_mm
5. Product Dimension L : \_\_\_\_\_mm
6. Product Dimension W : \_\_\_\_\_mm
7. Product Dimension H : \_\_\_\_\_mm
8. Product weight : \_\_\_\_\_Kg
9. Product Spacing : \_\_\_\_\_mm
10. Temperature in Contact Zone : \_\_\_\_\_°C
11. Max. Speed : \_\_\_\_\_M/Min
12. Speed adjustable : Required (\_\_\_\_ - \_\_\_\_M/Min)  
Not Required
13. Voltage 、 Frequency : \_\_\_\_\_ V  
\_\_\_\_\_ Hz  
\_\_\_\_\_ Phase
14. Frame Materials : Stainless steel  
Painted Mild steel
15. Side Guard : 25mm 120mm Other\_\_\_\_\_

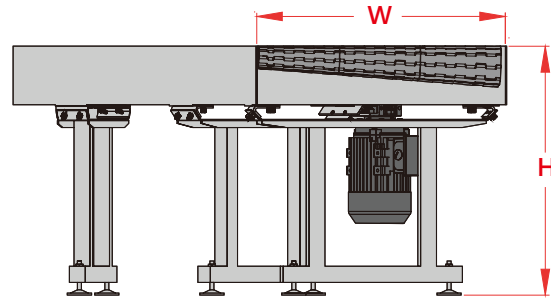

**Contact Information**

Company Name : \_\_\_\_\_  
 Contact Person : \_\_\_\_\_ Department : \_\_\_\_\_  
 Phone : \_\_\_\_\_ Fax : \_\_\_\_\_  
 Website : \_\_\_\_\_ Email : \_\_\_\_\_